

Application example

Xtra·tec® XT Shoulder milling cutter M5130

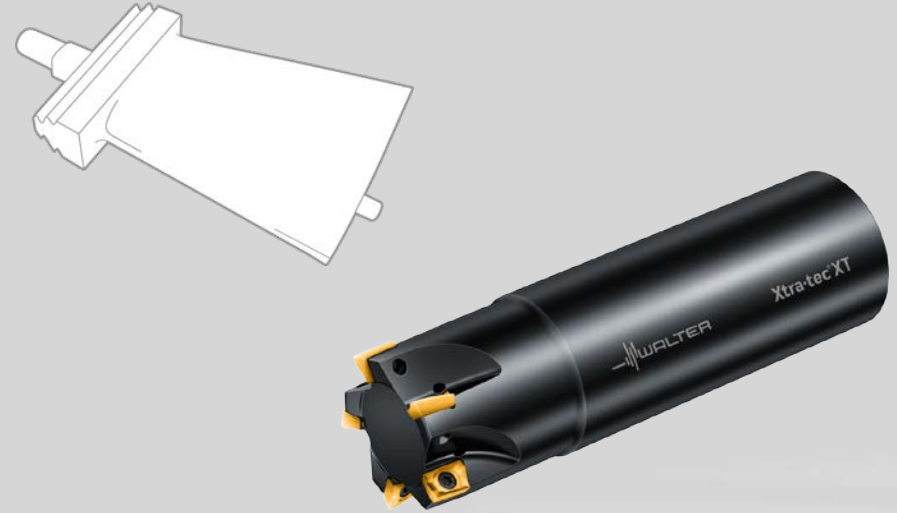

Work piece	Rotor blades	
Material	X22CrMoV12-1	
Operation	Semi finishing	
Tool	M5130-016-W16-04-05	
Insert	ACMT060216R-G55	
Grade	WKP35G	
	Competition	Walter
z Number of teeth	2	4
v_c [m/min]	156	240
f_z [mm]	0,23	0,25
v_f [mm/min]	1399	4775
a_p [mm]	0,8	0,8
a_e [mm]	16	16

Compare: Feed rate [mm/min]

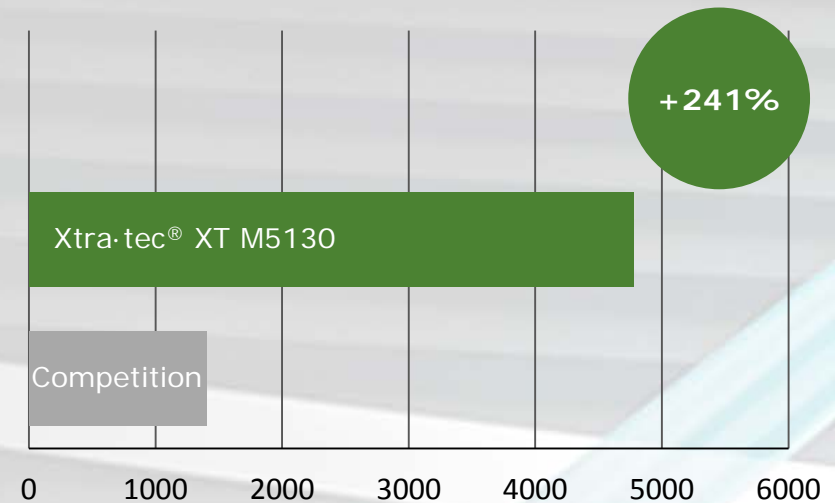

Application example

Xtra·tec® XT Shoulder milling cutter M5130



Work piece	Sprocket	
Material	18 CrNiMo 7-6	
Operation	Slot milling	
Tool	M5130-025-TC10-05-05	
Insert	ACMT060204R-G55	
Grade	WSP45S	
	Competition	Walter
z Number of teeth	3	5
v_c [m/min]	140	100
f_z [mm]	0,13	0,12
v_f [mm/min]	668	764
a_p [mm]	1,18	1,8
a_e [mm]	25	25

Comparison: Tool life [slots]

