

Submit To: **Walter USA**

Distributor	Distributor No.	Contact Person
Customer	Customer No.	Contact Person
E-mail	Telephone	Fax
FSE Name	Inquiry Date	Expected Date of Quote

Quantities:

cutting-Ø < 6 3 - 100 pcs., Ø 6 ≤ cutting-Ø < 20 3 - 50 pcs
 Ø 20 ≤ cutting-Ø ≤ 25 3 - 30 pcs.

All length and diameter measures without units in inch

Workpiece material:

Material hardness:
(N/mm² or HRC)

ae
ap

Application:

Side and face milling /
slot milling / pocket milling

copying

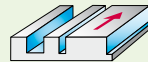

Slot drills

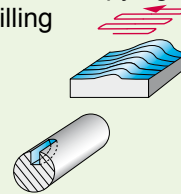

Coolant supply

external
dry

Lubricant:

Face geometry:

sharp corner

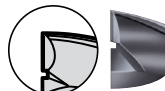

R:

Radius at corner

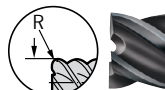

l₁₁:

Corner chamfer

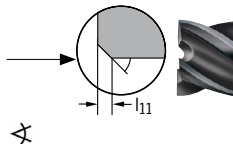

Center cut:

with center cut
without center cut

No. of teeth:

Construction Dimensions:

D_c: min. .079", max. 1"
Tol. Tol.-Field min. IT8

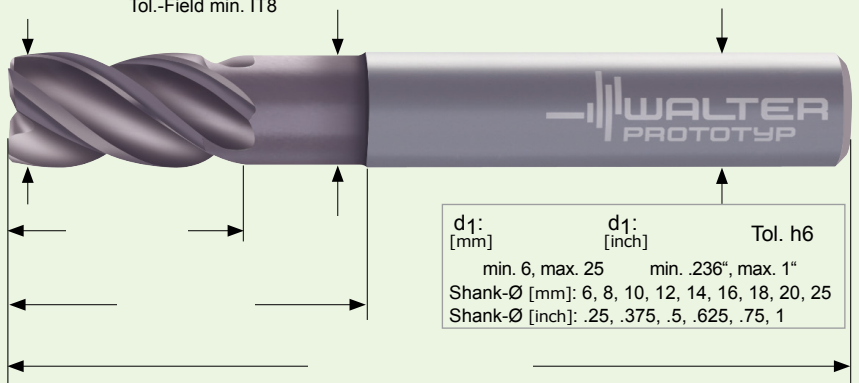

d ₁ : [mm]	d ₁ : [inch]	Tol. h6
min. 6, max. 25	min. .236", max. 1"	
Shank-Ø [mm]: 6, 8, 10, 12, 14, 16, 18, 20, 25		
Shank-Ø [inch]: .25, .375, .5, .625, .75, 1		

Selection tool type:

Cone-Fit
Solid carbide

End mill sub group:

- | | |
|------------------|------------------------|
| Protomax™ ST N45 | Protostar® N50 |
| Protomax™ ST N50 | Protostar® AL30 |
| MC 326 | Protostar® AL45 |
| MC726 | Protostar® Compact N45 |
| Protostar® N30 | |
| Protostar® N40 | |
| Protostar® N45 | |

Coating:

- none
- TAT*
- TAZ
- ACN

Type of shank DIN 6535:

- HA
- HE
- HB
- Safelock™

Comments:

Shipment of the tool within 5 weeks from Germany. (*TAT within 6 weeks). Additional information about Walter Xpress you will find at www.walter-tools.com

All green highlighted fields are mandatory fields to design the special tool. The other input fields are optional.